



The Johnston V Range

VT501 VS501

VT651 VS651

VT801 VS801



FM 83396



EMS 533329



OHS 543760

Extraordinary results from our popular machines

The V Range has established itself as Johnston's most reliable and dependable truck mounted sweeper. The Latest V Range sweepers have been developed from over 50 years of evolution and continuous improvement to meet customer requirements.

With sweepers tailored to operate in many specific environments, Johnston offers a wide choice of products and options, which ensures maximum performance is always achieved.

Operational Performance

The V Range is designed to fit a wide range of chassis models to suit specific operational requirements, confident that the Johnston V Range sweeper will provide the power and performance to complete the task.



- In-cab controls are ergonomically positioned to provide safe and easy operation whilst sweeping.
- The CANbus system monitors sweeper performance and provides daily checks. The display incorporates as standard an audible and visual raised hopper warning, fuel gauge, engine hour meter, tachometer and a water level gauge. In addition, data can be downloaded via a USB, showing a range of information from fuel consumption to average sweeping times.
- Throttle control of the auxiliary engine is infinitely variable ensuring optimum operational and fuel efficiency without compromising performance. With a 1500 rev Eco-mode built into the V Range, fuel conservation is enhanced and noise levels are reduced.
- A full CANbus integrated door mounted control pad allows the operator to safely adjust all the sweep options.
- Pendant controls connected via a flexible cable allows the operator to safely tip the body and open the rear door from either side of the cab, at the same time maintaining a clear view of the tipping area.
- To extend brush life, the wide-sweep brush can also be adjusted using the pendant control.
- As standard, all Johnston V Range sweepers are fitted with a body prop which automatically engages when the hopper is raised, and has a choice of four tipping heights.
- The auxiliary engine and hydrostatic drive pumps are accessed via a wide lightweight service ladder giving constant three-points of contact for the user.
- All V Range models have equipment lockers on both sides of the hopper for storage of hydrant or Wanderhose extension tubes.
- All critical controls – including valves, solenoids and auxiliary equipment for pneumatic, hydraulic and water systems are contained in a purpose built locker on the right hand side of the vehicle. The ease of access to this equipment aids diagnostic checks and maintenance. Additionally, the V Range is also fitted with waterproof IP67 automotive electrical connectors for enhanced reliability.
- As standard, the V Range sweeper features a Pressadrain water purging system so that when freezing weather conditions are anticipated, water is easily and conveniently drained by operating a simple in-cab switch.
- Water jets in the nozzle boxes are self-cleaning which extends the life of the components.

TOP
Pendant control for safely raising the hopper

MIDDLE
CANbus system

BOTTOM
Convenient door mounted control pad

Productivity

The V Range provides the ideal balance between performance, environmental impact and low cost of ownership, with applications to suit a full range of sweeping environments - benefits that make the Johnston V Range the sweeper of choice worldwide.

Two drive options (VT and VS) provide outstanding vacuum performance. On the VT Range, JCB auxiliary engines combined with the Johnston mechanical step-up gear box and fluid coupling, and the Johnston hydrostatic gear box drive on the VS model, provide the best efficiency ratios in the industry.

The versatile VT Range powerpack with a range of 1200 rpm – 2000 rpm, can operate efficiently in municipal environments at a lower rpm, or for one pass heavy duty resurfacing operations, the engine provides full power to ensure a clean path is all that is left behind.

There are a choice of three sweeping configurations, left hand or right hand sweeping which provides a swept width of up to 2400mm, and simultaneous sweeping which gives a swept width of up to 3600mm.

A stainless steel water tank is integrated into the floor of the hopper body, which provides ideal weight distribution between axles, and weight transfer during sweeping. For increased productivity, an optional water recirculation system can be installed on the V651 and V801, which can double on-station time before water refilling with the added advantage of reducing dust emissions.

Dust and debris are collected by pneumatically operated vacuum nozzles and wide diameter 250mm nozzle trunking, maximising velocity and allowing larger debris to pass easily into the hopper.

Debris is sucked in a direct route from the vacuum nozzle into the hopper, reducing wear and tear as well as maintenance. Once in the hopper, the Johnston cyclonic airflow helps separate the debris, and clean air is then released into the atmosphere.



FAR LEFT
Brush gear at work

MIDDLE
Versatile Littasnatch option

BOTTOM
Accessible systems locker





Johnston VT/VS Range comes with a choice of hopper options:

- The V501 truck mounted sweeper has a 5.1m³ hopper volume and 1360 litres capacity water tank. The Johnston V501 is fitted to a shorter wheelbase chassis, but still has the same power train and many of the options as the V651. With a lighter body the V501 retains a 4,400kg payload on a GVW 12T chassis.
- The popular Johnston V651 has a hopper volume of 6.5m³ water tank capacity of 1572 litres. The V651 is compatible with GVW 13-15T chassis.
- A Johnston V801 truck mounted sweeper comes with a high powered engine as standard and a hopper volume of 8m³. The water tank capacity is increased to 2023 litres and is well matched to a GVW 15-18T chassis.

All Johnston V Range models are built with an angled hopper floor, enabling a total discharge angle of 53-56° (model dependent) to aid load discharge.

TOP RIGHT
Rotatilt Brush Option

MIDDLE RIGHT
Ideal in a city environment

BOTTOM RIGHT
VT651 in transit



Environmental Impact

Manufactured in a factory accredited to ISO 14001 for sustainability, Johnston is committed to providing the most environmentally sustainable equipment on the market for collecting all types of debris and litter.

Low fuel consumption is a key attribute in reducing carbon footprint and CO₂ emissions. With the mechanical drive systems running at maximum efficiency, the fuel consumption of the auxiliary engine is the lowest in its class with 3.3 litres per hour at 1200 rpm.

The VT Range is now fitted with auxiliary engines supplied by JCB, whose engines meet the highest standards for emissions and environmental impact.

The Johnston system for suppression of dust emissions easily achieves EUnited PM10 standards in Europe and SCAQMD Rule 1186 in the USA.

Water recirculation not only provides extended sweeping shifts but can also save 900 litres of water per day over an 8 hour shift.

The V Range sweepers are equipped with noise suppression hoods, encapsulating the auxiliary engine and fan casing. Noise at the driver's ear is less than 75dB(A) at maximum revs (chassis dependant), creating a safer operating environment for both driver and pedestrians. The fully variable engine can be set to lower revs for night sweeping which reduces noise levels by 50%.

The Johnston V Range is robustly constructed from quality materials and designed to provide years of continuous performance and reliable service. End of life disposal is enhanced by the V Range sweeper being almost 100% recyclable.

ABOVE
Ideal for a variety of
sweeping applications

Additional Features

Johnston provides a comprehensive choice of options all designed to maximise versatility and performance:

- Supawash – a high pressure water jet, enables the operator to clean street furniture and pavements using either a fan or pencil jet spray. The lance and hose stows away neatly when not in use. In addition, high pressure water jets on a spray bar are positioned on the front of the cab, and others placed behind the nozzle boxes to provide dust suppression when sweeping.
- An optional Wanderhose mounted on the top of the hopper can be fitted to allow the emptying of drains along the sweeping route. If “Powaboom” is selected, controls are fitted to make movement and operation of the boom convenient, whilst the top-mounted position provides greater access to both sides of the sweeper and also shields the driver from oncoming traffic.
- Combivac Nozzles – for faster sweeping with an additional brush at the rear of the vacuum nozzle.
- Rear mounted Littasnatch, with a 5.5m long lightweight suction tube for collection of debris on pavements and areas out of reach of the sweeper brushes.
- Rotatilt – controlled from inside the cab, this option allows the channel brush to tilt and sweep in cambered kerbs and gutters.
- Weed Ripping Brush – a heavy duty brush with thick metal tines that effectively clears vegetation that has become established in gutters.



TOP ROW (LEFT)
Wanderhose, picks up bulky
and heavy objects

TOP ROW (RIGHT)
Dust suppression spray jets

BOTTOM ROW (LEFT)
Supawash hand lance

BOTTOM ROW (RIGHT)
Combivac nozzle



Hydrostatic Drive

The V Range hydrostatic sweeper model is powered by Johnston's hydrostatic drive system. The gearbox is powered by the main truck chassis engine and enables infinitely variable forward speed control. Designed by Johnston specifically for road sweeping, the hydro-drive allows for cruise control and travel speeds up to 40 kph in hydrostatic drive, reducing the need to de-select hydrostatic drive when travelling short distances

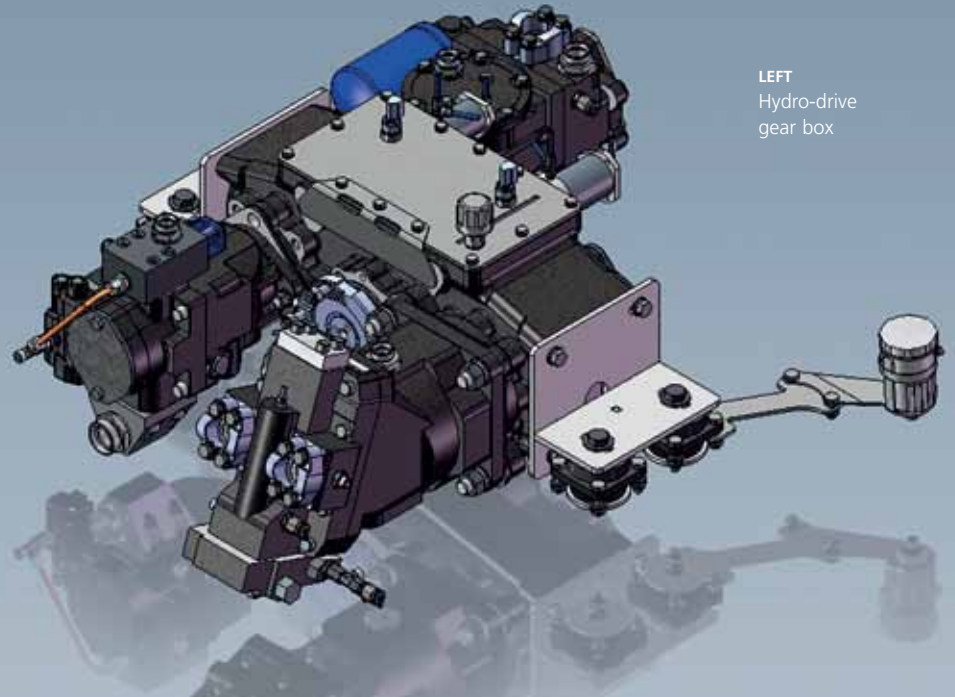

LEFT
Hydro-drive
gear box



TOP
High pressure deep cleaning line
& gutter jet option

BOTTOM
Additional full width nozzle option

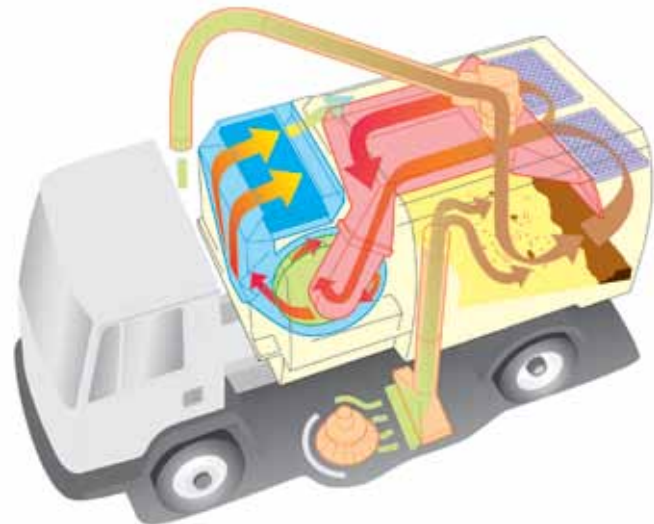

Cost of Ownership

V Range sweepers operate at the lowest costs, with a large 190 litre auxiliary fuel tank giving increased on-station time. In addition, maintenance costs are significantly reduced on the Johnston gearbox and fluid coupling, as no belts or high wearing components are required.

Johnston's VT Range provides the lowest emissions and running costs. The VT and VS models operate at low fuel consumption with both the chassis and auxiliary engines using a total of 5.05 l/hr at low rpm. In addition, suction sweeping requires fewer component parts, thus resulting in less wear and tear and reducing maintenance costs.

Designed to last in the toughest environments, the V Range hopper is manufactured from 4003 stainless steel, shot blasted with aluminium oxide prior to the application of a strontium based primer followed by a hard wearing top coat. In addition, all grey parts such as the sweepgear, powerpack and subframe are shot blasted and electro-magnetically powder painted in a durable two part epoxy paint finish. This ensures the sweeper continues to look as good as it performs, retaining a high residual value or longer in-service life.

Outline Specification V Range

VT501 / VS501

Payload capacity: up to 3-4 tonnes nominal (depending on chassis selection)

Clean water tank capacity: 1360 litres

Hopper void: 5.1 m³ nominal

Swept width: 3400 mm (Max)

Chassis GVM: 9.5-12 tonnes

Auxiliary fuel tank: 190 litres

VT651 / VS651

Payload capacity: up to 6 tonnes nominal (depending on chassis selection)

Clean water tank capacity: 1572 litres

Additional water capacity recirculation option: 750 litres

Hopper void: 6.5m³ nominal

Swept width: 3600 mm (Max)

Chassis GVM: 13-15 tonnes

Auxiliary fuel tank: 190 litres

VT801 / VS801

Payload capacity: up to 7 tonnes nominal (depending on chassis selection)

Clean water tank capacity: 2023 litres

Additional water capacity recirculation option: 750 litres (approx)

Hopper void: 8m³ nominal

Swept width: 3600 mm (Max)

Chassis GVM: 15-18 tonnes

Auxiliary fuel tank: 190 litres

Water Recirculation System

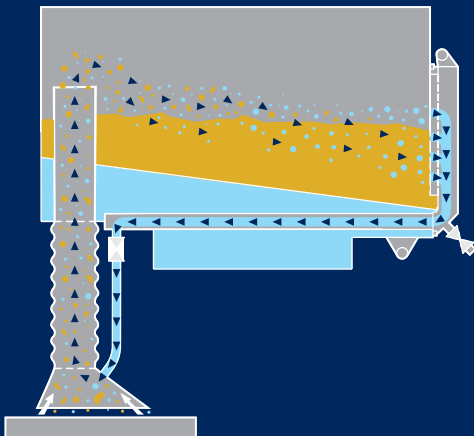

VT Range Powerpack

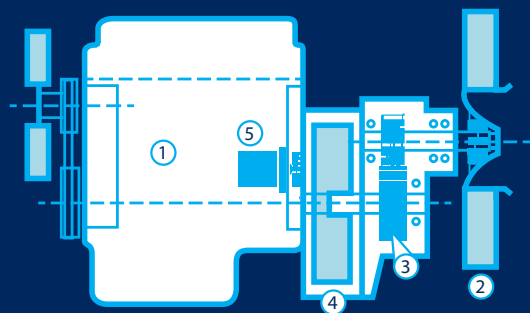

- 1 Engine
- 2 Exhaust fan impeller
- 3 Step-up gearbox

- 4 Fluid flywheel coupling
- 5 Gear driven hydraulic pump

Johnston Sweepers

Curtis Road, Dorking, Surrey RH4 1XF, UK

Tel: +44 (0)1306 884722

Fax: +44 (0)1306 884151

Email: enquiries@johnstonsweepers.com

www.johnstonsweepers.com